

Original-Operating manual

High-pressure cleaners

- GB

quadro 800
250 bar / 3600 psi **TST**

quadro 1000
220 bar / 3200 psi **TST**

quadro 1200
180 bar / 2600 psi **TST**

quadro 1000
220 bar / 3200 psi **TS**

quadro 1200
180 bar / 2600 psi **TS**



Read and conform safety instructions before use!

Keep instructions in a safe place for later use and pass them on to any future user.



Technical data

Technical data	quadro 800 TST	quadro 1000 TST	quadro 1200 TST	quadro 1000 TS	quadro 1200 TS
Operating pressure, steplessly adjustable	30 - 250 bar	30 - 220 bar	30 - 180 bar	30 - 220 bar	30 - 180 bar
Perm. overpressure	270 bar	250 bar	200 bar	250 bar	200 bar
Water output ^(*) at 0 bar	15 l/min	17,5 l/min	21 l/min	17,5 l/min	21 l/min
at nominal pressure	13,5 l/min	15,6 l/min	19 l/min	15,6 l/min	19 l/min
Nozzle size (Flat jet)	2504	2505	2507	2505	2507
(Turbokiller)	04	055	08		
Volume					
Water tank	16 l	16 l	16 l	16 l	16 l
Max. inlet water temperature to water tank	max. 60 °C	max. 60 °C	max. 60 °C	max. 60 °C	max. 60 °C
Direct suction height	2,5 m	2,5 m	2,5 m	2,5 m	2,5 m
Hose drum	yes	yes	yes	no	no
High pressure hose	20 m	20 m	20 m	10 m	10 m
Electrical ratings	400 V/50 Hz 12 A	400 V/50 Hz 12 A	400 V/50 Hz 12 A	400 V/50 Hz 12 A	400 V/50 Hz 12 A
Motor speed adjustm.	1400 U/min	1400 U/min	1400 U/min	1400 U/min	1400 U/min
Connect. wattage inp. output.	P1: 7,5 kW P2: 5,5 kW	P1: 7,5 kW P2: 5,5 kW	P1: 7,5 kW P2: 5,5 kW	P1: 7,5 kW P2: 5,5 kW	P1: 7,5 kW P2: 5,5 kW
Weight (incl. accessories with empty water tank)	89 kg	89 kg	89 kg	82 kg	82 kg
Dimensions including handle L x W x H in mm	770 x 570 x 990	770 x 570 x 990	770 x 570 x 990	770 x 570 x 990	770 x 570 x 990
Sound level acc. to 45 635 (rel. to working place) with Turbokiller	89 dB (A)	89 dB (A)	89 dB (A)	89 dB (A)	89 dB (A)
Guaranteed sound level LWA	91 dB (A)	91 dB (A)	91 dB (A)	91 dB (A)	91 dB (A)
Vibrations at lance	2,2 m/s ²	2,2 m/s ²	2,2 m/s ²	2,2 m/s ²	2,2 m/s ²
Recoil at lance	ap. 20 N	ap. 20 N	ap. 22 N	ap. 20 N	ap. 22 N
Order n°.	40.423	40.421	40.422	40.421 1	40.422 1

Permissible tolerance for figures ± 5 % in acc. with VDMA uniform sheet 24411

^(*) **Min. water quantity to be supplied to the high pressure cleaner!**
(2-8 bar admission pressure)

Description

Dear customer

We would like to congratulate you on your new high pressure cleaner with integrated water tank and to thank you for the purchase.

To ease your introduction to the use of the cleaner, we have provided the following pages of explanations, tips and hints, which we ask you to read before using for the first time.

The equipment will assist you professionally in all cleaning tasks, e.g.:

- **facades**
- **vehicles of all types**
- **barrels and containers**
- **flagstones**
- **containers**
- **channels**
- **terraces**
- **machines etc.**

Contents

	Side
Technical data	2
Construction and components	4
Water system	5
Detergent / caring system	5
Lance and spay gun.....	5
High pressure hose and spray device.....	6
Unloader valve - safety valve.....	6
Delayed motor cut-out.....	7
Safety cut-out.....	7
Setting up / Location	7
Electrical connection	8
Brake.....	9
Brief operating instructions.....	9
This is what you've purchased.....	10
How to assemble and furnish your HP cleaner	11
Preparation for use.....	12
External suction.....	13
When using detergents	14
To shut down the pump / Frost protection	14
Safety notes „This is prohibited !“.....	15
Additional accessories	18
Small repairs	20
Spare parts lists	22
General rules.....	39
Inspection report	40
Declaration of conformity	43

Description

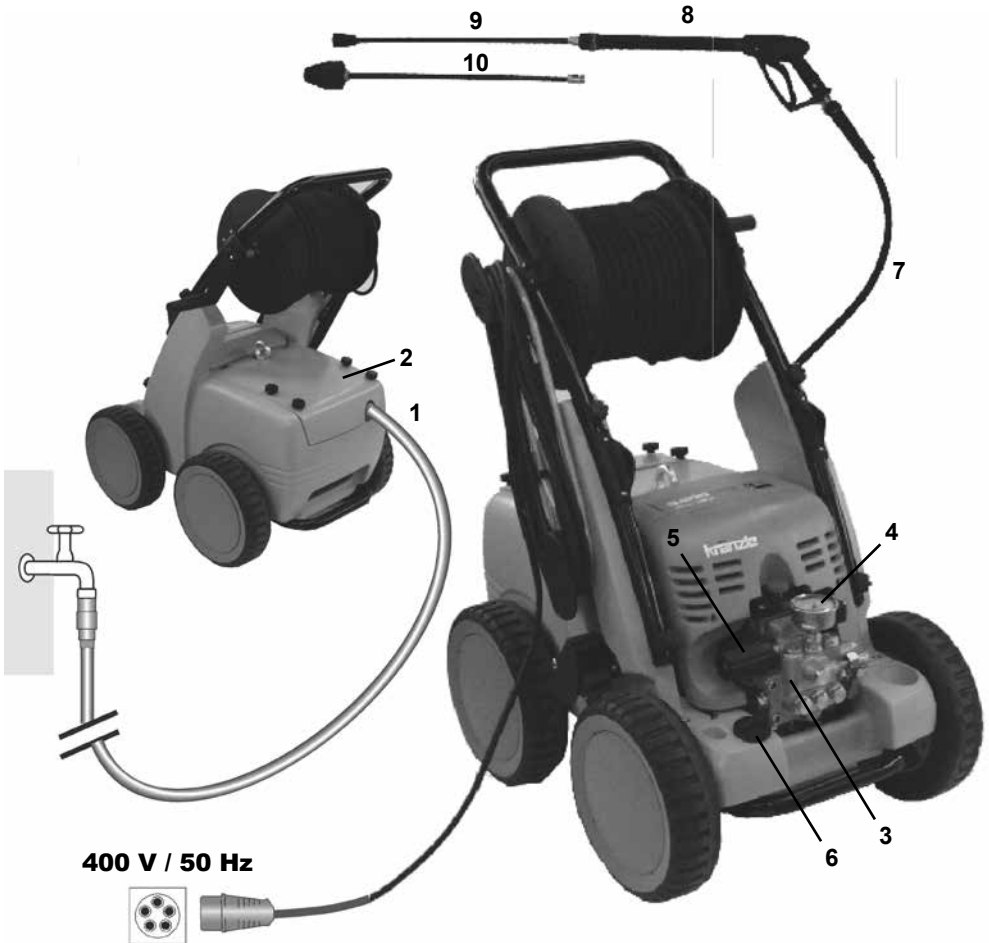

Construction

The KRÄNZLE quadro 800 TST, 1000 TST and 1200 TST TST high pressure cleaners are mobile machines with hose drum and 20m industrial hose. The KRÄNZLE quadro 1000 TS und 1200 TS - high pressure cleaners are mobile machines without hose drum, however with 10m industrial hose. The schematic principle can be seen from the illustration.

Components

- | | |
|--------------------------------------|---|
| 1 Water inlet connection with filter | 6 Detergent valve |
| 2 Cover for water tank | 7 High pressure hose |
| 3 High pressure pump | 8 Spray gun |
| 4 Press. gauge with glycerin filling | 9 Interchangeable lance with Turbokiller |
| 5 Unloader valve - safety valve | 10 Interchangeable lance with flat jet nozzle and nozzle protection |

Description

Water system

The water must be lead to the high pressure cleaner under pressure (2 – 8 bar ad-mission pressure). A float valve regulates the water inlet. Then, the water is sucked by the high pressure pump from the water tank and supplied to the lance under the set pressure. The high pressure jet is formed by the nozzle at the end of the lance.

Detergent and caring system

The high pressure pump can also suck a detergent/caring agent and mix it with the high pressure jet. The additive is sucked through the pump and brought in with the set pressure. Insert the detergent hose into the detergent container and open the detergent valve (6). The detergent discharges with the water at the high pressure nozzle.



Open the dosing valve, if the chemistry sieve is placed in a liquid. Sucked air leads to destruction of the pump seals!!!

The rules concerning the environment, refuse and ground water protection must be complied with!

Lance with spray gun

The machine can only be operated when the safety trigger is squeezed.

When the lever is squeezed, the spray gun opens. The liquid is then pumped to the nozzle. The spray pressure increases and quickly reaches the selected operating pressure.

When the trigger is released, the trigger gun closes and any further spraying of liquid from the lance is stopped and the manometer must show 0 bar.

The increase in pressure when the trigger gun is closed causes the unloader valve-safety valve to open. The pump remains switched on and continues to pump liquid through the pump at reduced pressure. When the spray gun is opened, the unloader valve - safety valve closes and the pump resumes spraying from the lance with the selected operating pressure.



The spray gun is a safety device. Repairs should only be performed by qualified persons. Should replacement parts be required, use only components authorized by the manufacturer.

Description

High pressure hose and spraying device

The high pressure hose and spraying device supplied with the machine are made of high grade material. They are also optimized for the machine and marked as required by the appropriate regulations.



Unloader valve - safety valve

The unloader valve - safety valve protects the machine from a build up of excess pressure, and is designed not to permit an excess pressure to be selected for operation. The limit nut on the handle is sealed with a spray coating.

The operating pressure and spray rate can be steplessly adjusted by turning the handle.



Replacements, repairs, new adjustments and sealing should only be performed by qualified persons.

Description



Delayed motor cut-out

Frequent, work-necessitated switching on and off of motors on machines of this size puts a heavy load on the power network and causes increased wear on internal electrical parts. Therefore the motor of the new KRANZLE device only switches off 30 seconds after closing the gun and then goes to stand still. By opening the gun, the device is started again.

Safety cut-out

If the device is accidentally not turned off after use or the pistol is not used for 20 minutes, the device automatically goes into the safety state via deactivating. By operating the main switch again, the device is activated again.



Replacements and inspection work should only be performed by qualified persons **when the machine is disconnected from the power supply, i.e. the plug pulled out from the electrical socket.**

Setting up

Location



Neither set up and operate the machine in rooms where there is a risk of fire or explosion nor put it into puddles. Do not use the machine under water. The device must not stand in the spray area of the high pressure jet.

CAUTION !



Never suck in liquid containing solvents such as paint thinners, petrol, oil or similar liquid matter. **Pay attention to the instructions of the manufacturers of the cleaning agents.** The seals in the machine are not resistant to solvents! The spray of solvents is inflammable, explosive and poisonous.

CAUTION !



When running your high pressure cleaner with hot water of 60° C raised temperatures occur. **Do not touch the machine without safety gloves!**

Description



Electrical connection

The machine is supplied with an electrical power cord with plug.

The mains plug must be fitted to a standard grounded socket with a **30mA** residual current operated device. The socket must be protected with a **16A delay** action fuse on the mains side.

KRÄNZLE quadro = 400 Volt / 50 Hz (phase-sequence not significant)

When using an extension cable, this must have a grounded lead which is properly connected to the socket. The conductors in the extension cable must have a minimum cross section of 1.5 mm². Plug connections must be of a spray-proof design and may not be located on a wet floor.

Description



Brake

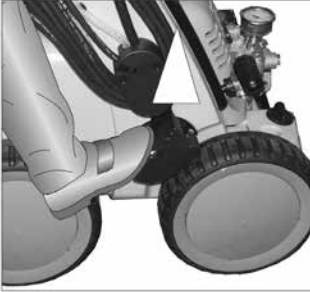

Brake applied



Brake not applied

Brief operating instructions

1. Connect high pressure hose with spray gun.
2. Connect to suitable water supply.
3. Connect current - (400 Volt three-phase current)
4. Switch on machine and start cleaning.
5. After having completed the cleaning process, put main switch in zero position and by opening the gun, reduce the pressure in the high pressure hose.

Then, the high pressure hose can be rolled up

- Only use clean water ! Protect from frost !

CAUTION !

Please pay attention to the regulations of your waterworks company.

Because of the water tank, the device can be connected to any drinking water line without worries.

This is what you've purchased:



- 1. Turbokiller**
Lance with nozzle protection and high pressure nozzle Flat jet 25°



- 2. Spray gun Starlet**
with insulated grip and screw connection



- 3. KRÄNZLE - High pressure cleaners**
quadro 800 TST, 1000 TST and quadro 1200 TST with hose drum
quadro 1000 TS and quadro 1200 TS without hose drum



- 4. Operating instructions**

- 5. High pressure hose, 20 m NW 8 on hose drum**

- 6. Crank for hose drum**

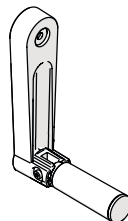

- 7. Water inlet part**
(filter is already installed)

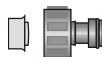

How to assemble and furnish your high pressure cleaner



Remove the screw from the drive shaft of the hose drum. Unpack the crank and insert it onto the hexagon head. Tighten the crank again with the screw.



To check the oil level, loosen the oil cover screw and take out the oil dip stick. The oil level must be between the two markings.



To control the high pressure cleaner
put

- 1. the foot against the tilt bases and then pull the device**
- 2. towards you.**

Preparation for use

1. Check oil level.

There are two possibilities for checking the oil level of the pump:

- a) Oil must be visible in the viewing window
- b) The oil state must be between the two markings on the oil measuring rod.

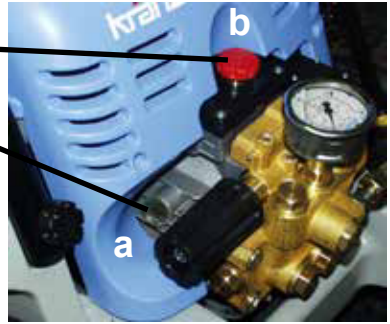

2. Connect the high pressure lance or Turbokiller to the spray gun.

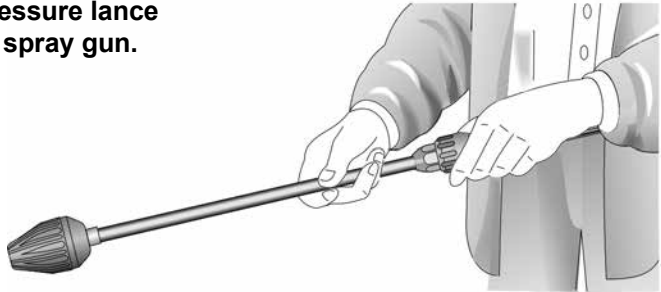

3. Unroll hose without kinks and connect with handgun and pump. Use max. 20 m HP hose.

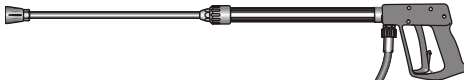
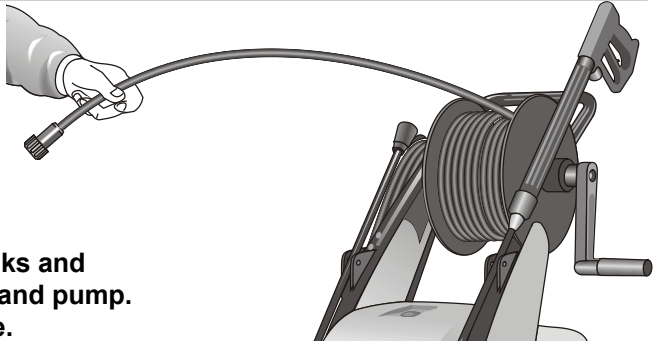

4. Connection of high pressure hose from device to lance

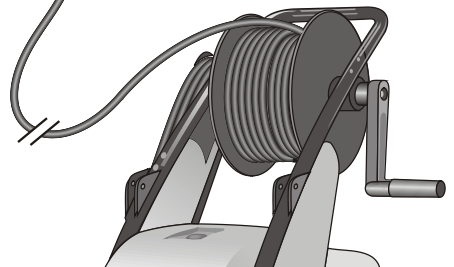

Preparation for use

5. The machine must be connected to the water line with cold water or up to 60° C warm water (see page 2).

The hose cross section must be at least 3/4" = 16 mm (free passage). Filter 1 must always be clean.

Please make sure that the filter is clean before using your high pressure cleaner.



CAUTION !



When running your high pressure cleaner with hot water of 60° C raised temperatures occur.

Do not touch the pump without safety gloves!

External suction



If water is to be sucked from an external container for the high pressure cleaner, the connection hose between the high pressure pump and the water tank must be screwed off and the suction hose must be connected directly to the pump.

Make sure that the water is clean. Use the Kränzle suction hose with suction filter. (Order N°. 15.038 3)

Maximum suction height 2.5 m, maximum water temperature for direct suction: 60°C (see technical data on page 2)

To shut down the pump

When using detergents:

Put chemistry sieve number 5 into the detergent container. Open the detergent valve, then the detergent is sucked in. When closing the detergent valve, the chemistry supply is automatically closed. Allow detergent to act and then wash off. (see page 5).



Note that you must always comply with the instructions provided by the manufacturer of the detergent (e.g. instructions concerning safety clothing) and the water protection regulations!

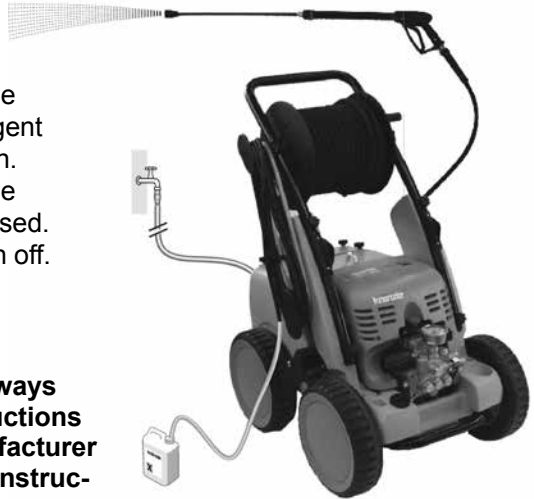

To shut down the pump:

1. Switch off the machine. Device switch to „0“ position.
2. Cut off the water supply.
3. Open the spray gun briefly until the pressure is released.
4. Apply the safety catch on the spray gun.
5. Remove the water hose and spray gun.
6. Pull the plug from the socket.
7. Winter: store the pump in rooms above 0°C.
8. Clean the water filter.

Safety notes

Frost protection

Normally after operation, there is still some water in the device. Thus, you must take special measures to protect the device from frost.

- **Completely drain the device**

For this purpose, separate the device from the water supply. Then, turn on the main switch and open the gun. Now, the pump presses the remaining water from the water tank and the pump. However, do not allow the device to operate without water for longer than one minute.

- **Fill the device with antifreeze agent**

If the device is not operated for longer periods, especially over the winter, you should pump an antifreeze agent through the device. For this purpose, fill the antifreeze agent into the water box and turn on the device. Wait with opened gun, until the agent comes from the nozzle.

However, the best way to protect the device from frost is to store it at a frost-free location.

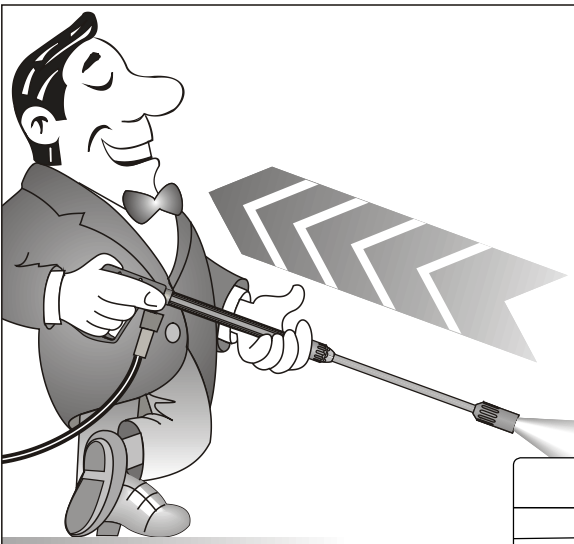

As to the recoil -
see notice on page 2!

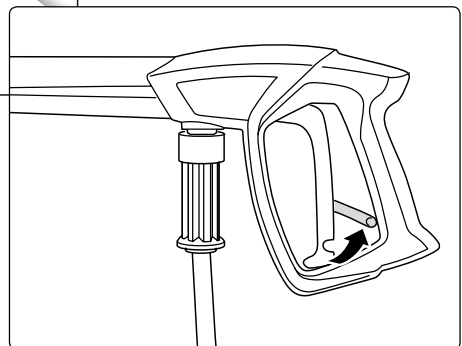

Apply the safety catch on the spray gun after each use, in order to prevent unintentional spraying!

This is prohibited !

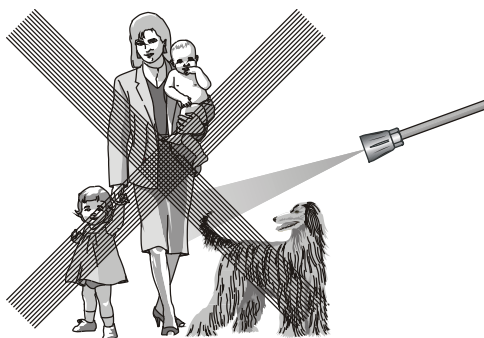

Never direct the water jet at people or animals !

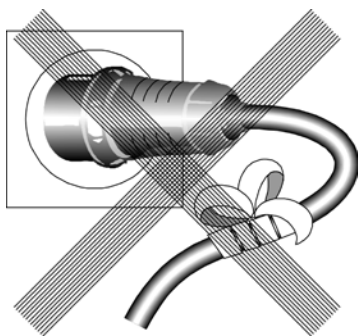

Do not damage the power cord or repair it incorrectly !



**Never pull the high pressure hose if it has formed kinks or “nooses”!
Never pull the hose over sharp edges !**

This is prohibited !

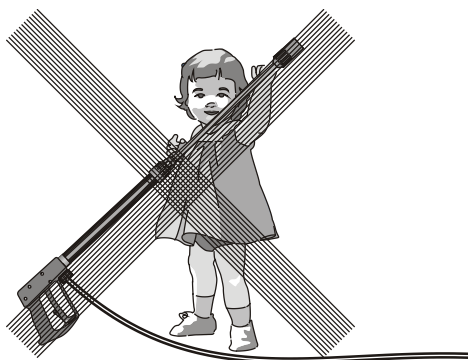

Never allow children to use the high pressure cleaner !

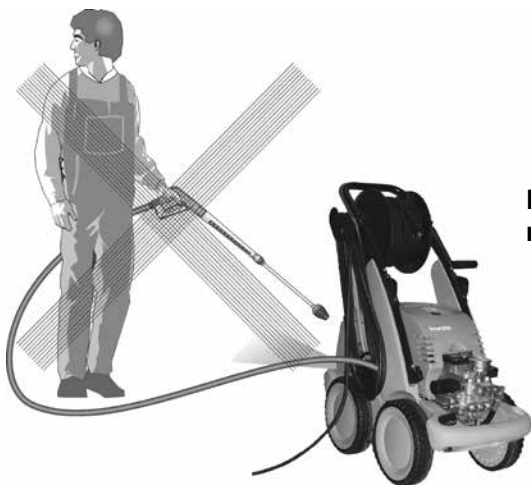

Never direct the water jet at the machine itself !

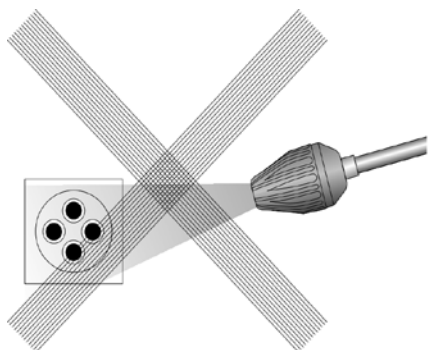

Never direct the water jet at a power socket !

Additional accessories for ... (on demand)



Rotary scrubbing brush
Order No. 41.050 1

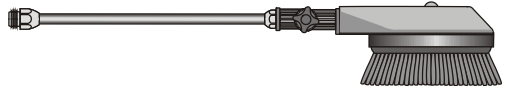

Drain and pipe cleaning hose
10 m - Order No. 41.058.1
15 m - Order No. 41.058

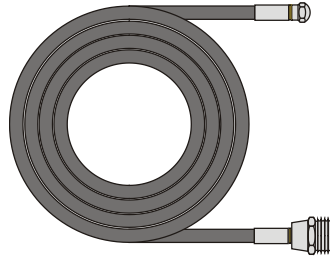

Environmental, refuse disposal and water protection regulations must be observed when using the accessories!

... further combination possibilities

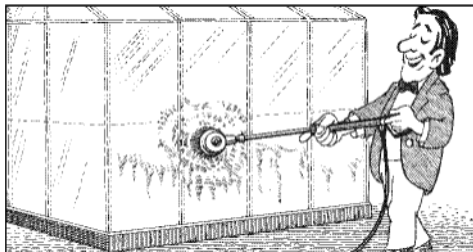

Car cleaning, glass, caravan, boat etc.:
rotary washing brush with 40 cm extension
and ST 30 nipple M22 x 1.5

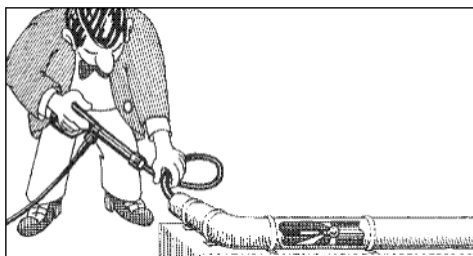

Cleaning pipes, channels and drains: pipe
cleaning hose with KN nozzle and ST 30
nipple M22 x 1.5

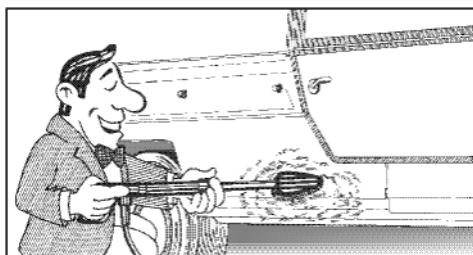

Cleaning cars and all smooth surfaces:
brush with ST 30 nipple M22 x 1.5

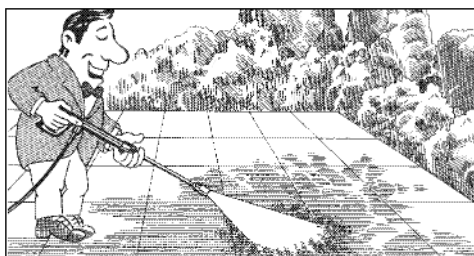

Rotary point sprayer for extreme soiling:
Turbokiller with 40 cm extension and ST 30
nipple M22 x 1.5

Small repairs ...

The nozzle is blocked!



- No water but the gauge shows full pressure !

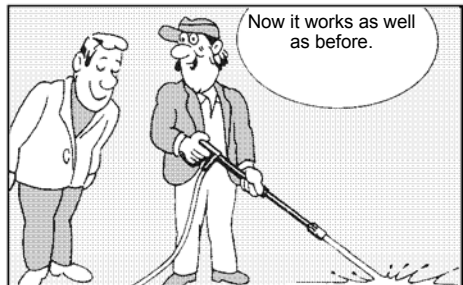
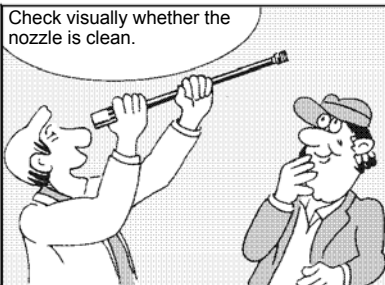
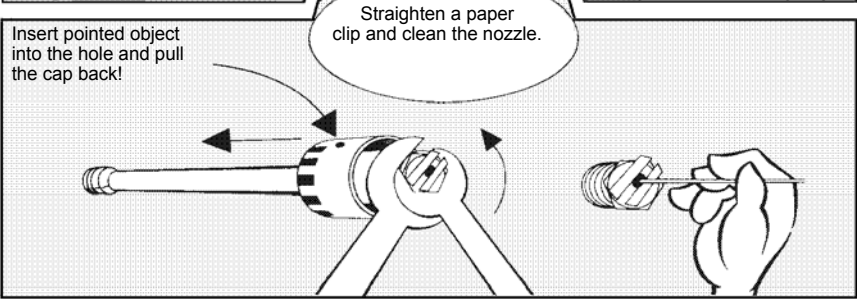
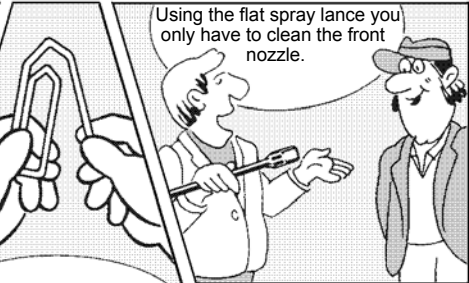
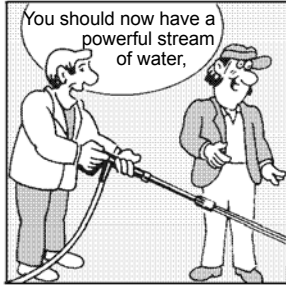
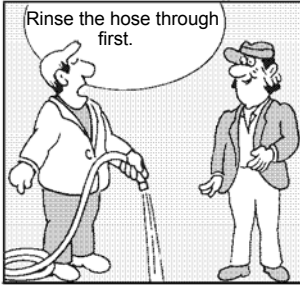

do it yourself !

Nozzle dirty or sticky!

- Pressure gauge does not show full pressure
- The high-pressure hose vibrates
- Water comes out in spurts.
- If you do not use the high-pressure cleaner for some time the valves can stick

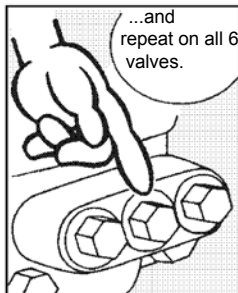
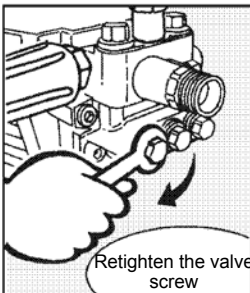
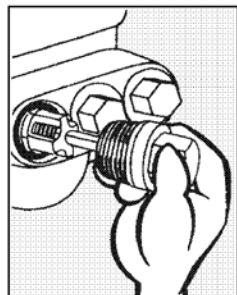
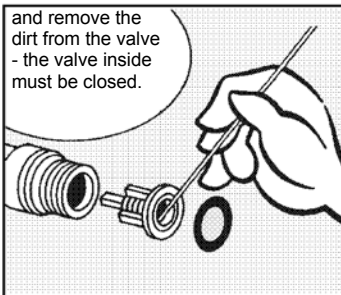
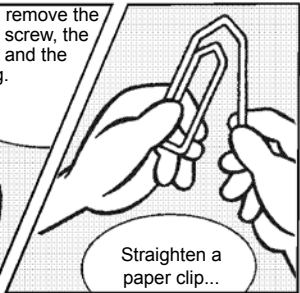
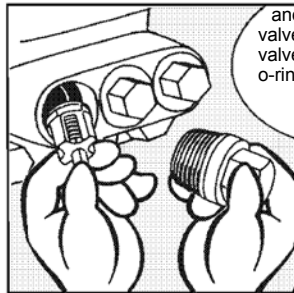
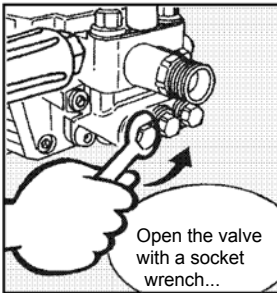
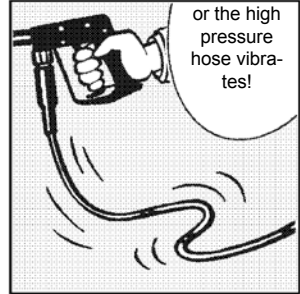
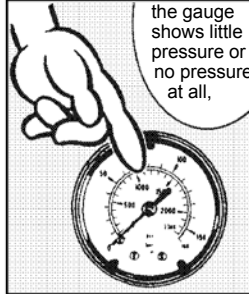
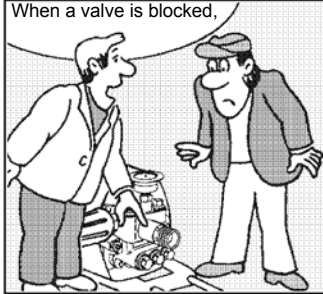

Complete Assembly

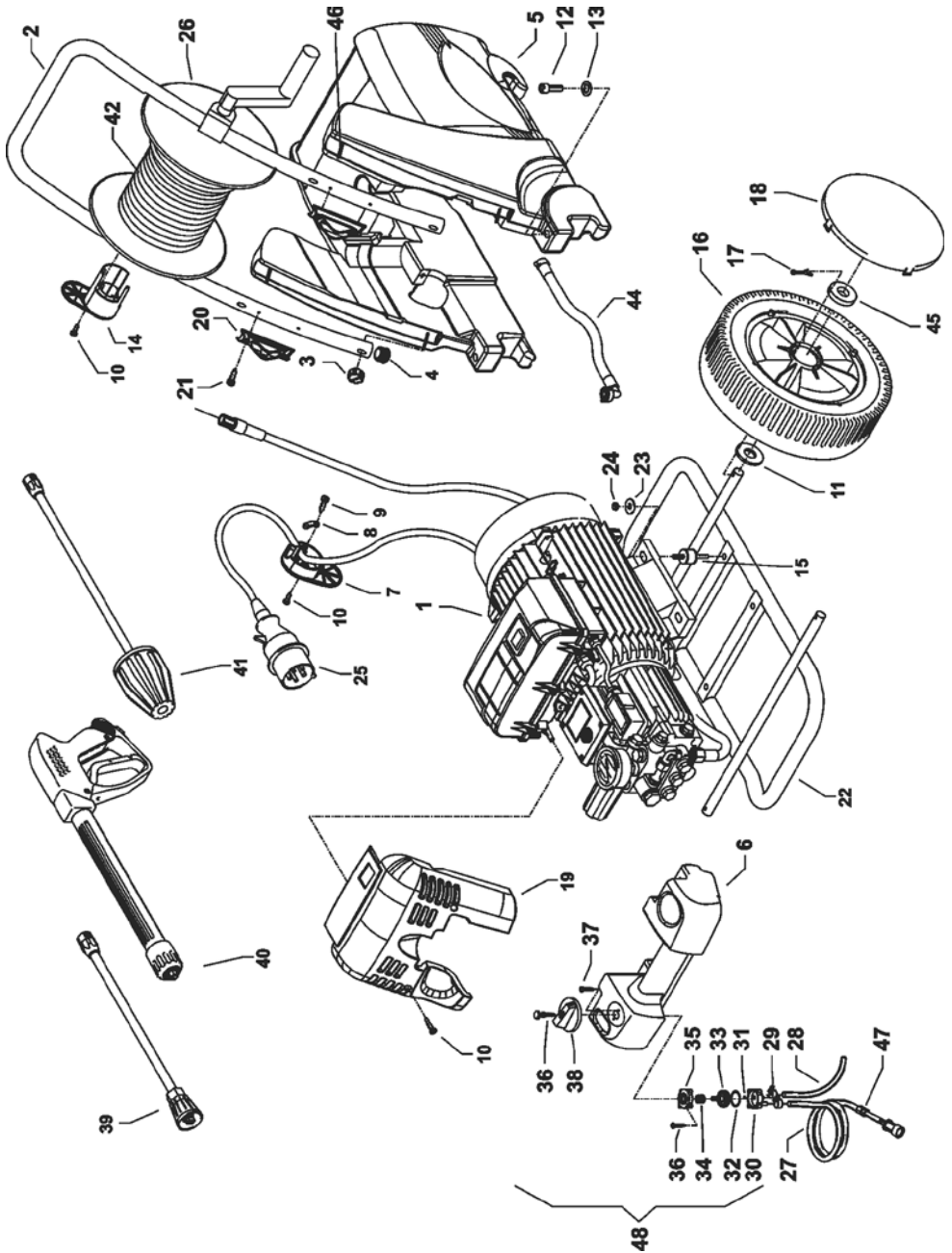

quadro 800 TST - 1200 TST

Spare parts list KRÄNZLE quadro 800 TST - 1200 TST Complete Assembly

No	Description	Qty.	Ord.-No	No	Description	Qty.	Ord.-No
1.1	Motor-Pumpe ohne Elektrik für quadro 800 TST	1	42.622 1	24	Elastic-Stop-Mutter M8	4	41.410
1.2	für quadro 1000 TST	1	42.622 2	25	Netzanschlusskabel 8 m	1	44.036
1.3	für quadro 1200 TST	1	42.622 3	26	Schlauchtrommel kpl.	1	41.259 6
1.4	für quadro 1000 TS	1	42.622 7	27	Chemiesaugschlauch (Gewebe) mit Filter	1	42.621
1.5	für quadro 1200 TS	1	42.622 8	28	Gewebeschnlauch 0,4m	1	42.622
2	Schubbügel	1	42.601	29	Schlauchklemme 9 - 9	2	44.054
3	Sterngriffmutter M8	4	42.619	30	Gehäuse Waschmittelventil	1	44.145
4	Stopfen	2	42.613	31	O-Ring 5 x 1,5 (Viton)	1	44.150
5	Wasserkasten	1	42.603	32	O-Ring 28,24 x 2,62	1	44.149
6	Lanzenablage	1	42.604	33	Regulierkolben Chemieventil	1	44.147
7	Kabelaufwicklung unten	1	42.611	34	Edelstahlfeder 1,8 x 15 x 15	1	44.148
8	Zugentlastung	1	43.431	35	Deckel für Chemieventil	1	44.146
9	Blechschaube 3,5 x 12	2	40.290	36	Blechschaube 3,5 x 16	3	44.161
10	Kunststoffschaube 5,0 x 25	6	41.414	37	Blechschaube 3,5 x 19	2	44.162
11	Scheibe 21 DIN125	12	40.207	38	Drehgriff Chemieventil mit Blendkappe	1	44.151
12	Schraube M8x50 DIN912	2	42.620	39.1	Lanze mit Flachstrahldüse für 800 TST	1	12.392-D2504
13	Scheibe 8,4 DIN125	2	50.186	39.2	Lanze mit Flachstrahldüse für 1000 TST	1	12.392-D2505
14	Kabelaufwicklung oben	1	42.612	39.3	Lanze mit Flachstrahldüse für 1200 TST	1	12.392-D2507
15	Gummipuffer 25 x 25	4	44.227	40	Starlett -Pistole mit Verlängerung	1	12.320 2
16	Rad	4	44.017	41.1	Turbo-Killer 04 bei quadro 800 TST	1	41.072
17	Splint 5x28 DIN94	4	42.614	41.2	Turbo-Killer 05 bei quadro 1000 TST	1	41.580-05
18	Radkappe	4	44.018	41.3	Turbo-Killer 07 bei quadro 1200 TST	1	41.072 7
19.1	Frontplatte quadro 800 TST	1	42.609 1	42	Hochdruckschlauch 20 m NW8	1	41.083
19.2	Frontplatte quadro 1000 TST	1	42.609 2	43	O-Ring 13 x 2,6	2	13.272
19.3	Frontplatte quadro 1200 TST	1	42.609 3	44	Verbindungsschlauch mit Winkel	1	42.625 1
20	Lanzenhalter	2	42.610	45	Scheibe 8mm für Rad	4	44.246
21	Blechschaube 3,5x16 DIN7981	4	44.161	46	Gewindestift M6x55	4	42.617 2
22	Fahgestell	1	42.602	47	Rückschlagventil für Chemiesaugschl.	1	44.240
23	Scheibe 8,4 DIN9021	4	41.409	48	Chemieventil Kpl. Pos. 30-37	1	44.052
				49	Wasserfilter	1	42.633

Brake

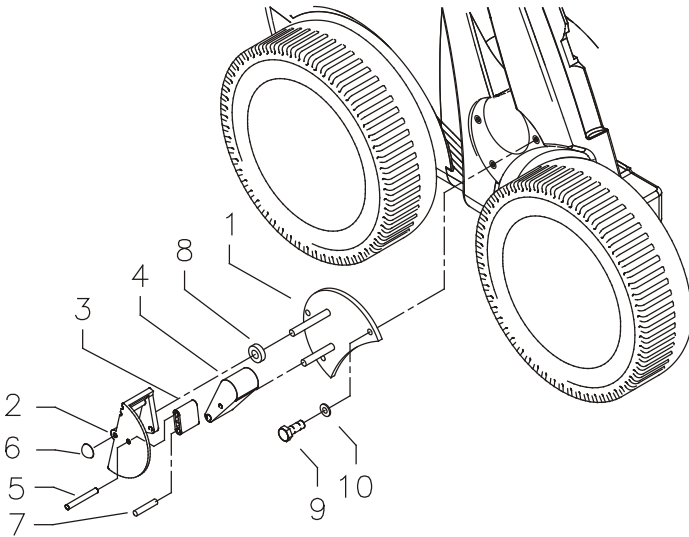

Spare parts list KRÄNZLE quadro 800 TST - 1200 TS Brake

No	Description	Qty.	Ord.-No
1	Grundplatte	1	42.615
2	Bremspedal	1	44.022
3	Bremshebel	1	44.023
4	Bremsklotz	1	44.024
5	Stift 6 x 50	1	44.035
6	Starlock-kappe 8 mm	1	44.165
7	Stift 6 x 40	1	44.035 1
8	Distanzring	2	42.626
9	Sechskantschraube M6x16	3	50.173
10	Unterlegscheibe DIN125-6,3	3	50.189

Water inlet

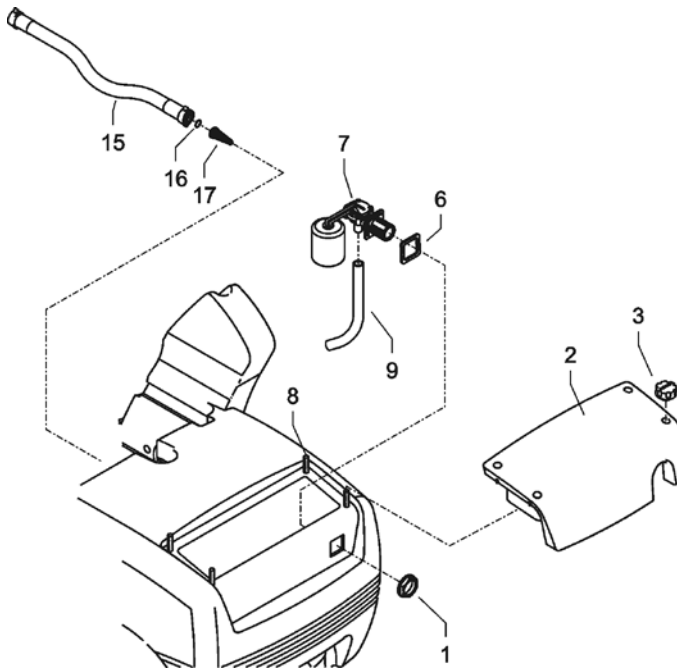

Spare parts list KRÄNZLE quadro 800 TST - 1200 TS Water inlet

No	Description	Qty.	Ord.-No
1	Mutter R3/4"	1	46.258
2	Revisionsdeckel	1	42.605
3	Sterngriffmutter M6	4	42.619
6	Dichtung für Schwimmventil	1	46.261
7	Schwimmventil	1	46.250
8	Gewindestift M6x40	4	42.617 1
9	Einströmschlauch	1	42.640
15	Verbindungsschlauch	1	42.625 1
16	O-Ring 15 x 1,5	1	12.256
16.1	O-Ring 13 x 2,6	1	13.272
17	Wasserfilter	1	42.633

Pump motor

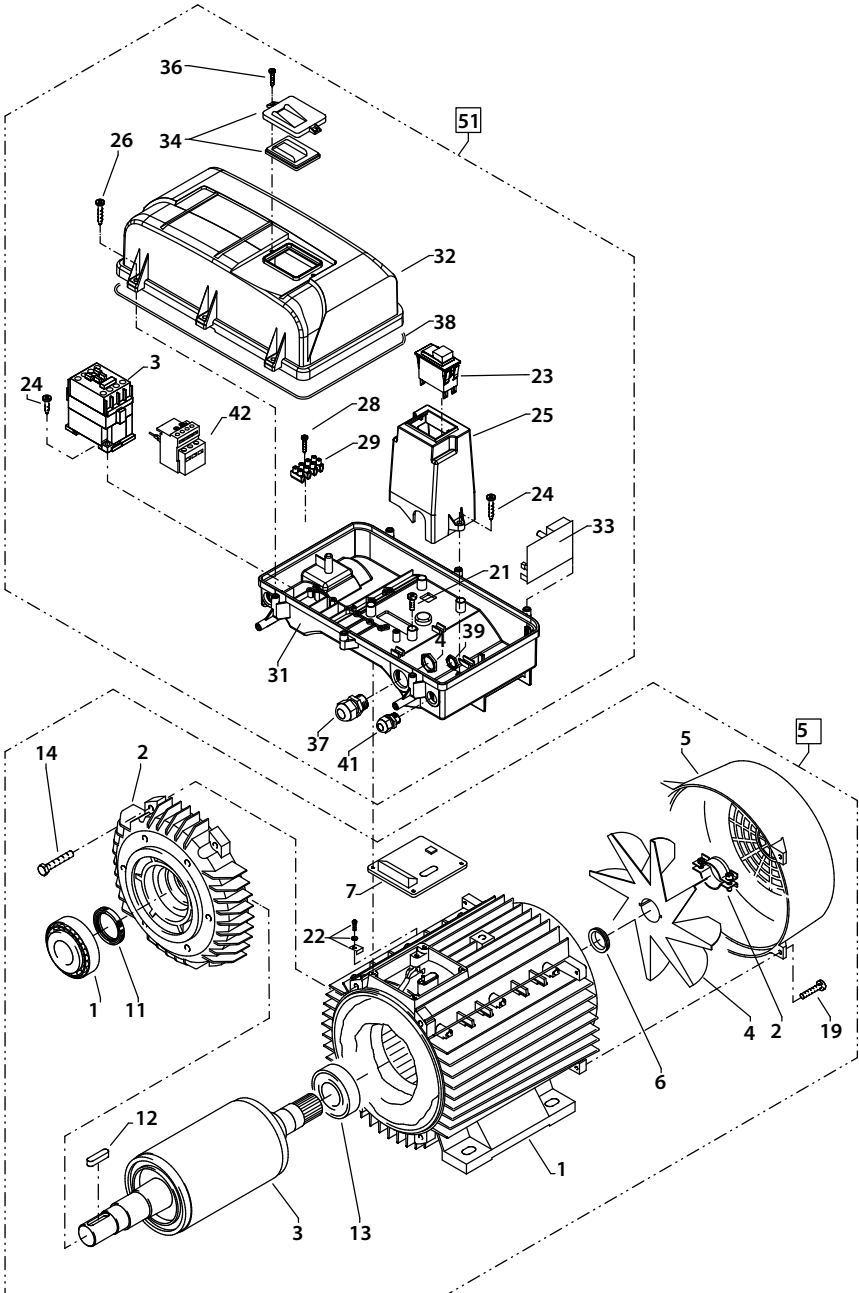

quadro 800 TST - 1200 TS

Spare parts list KRÄNZLE quadro 800 TST - 1200 TS Pump motor

No	Description	Qty.	Ord.-No
1	Stator 112 5,5kW 400V / 50Hz	1	40.540
2	A-Lager Flansch	1	40.530
3	Rotor 112 (400V / 50Hz)	1	40.531 5
4	Lüfterrad für BG 112	1	40.532
5	Lüfterhaube BG 112	1	40.533
6	V-Seal	1	40.545
7	Flachdichtung	1	43.030
10	Kegelrollenlager 31306	1	40.103
11	Öldichtung 35 x 47 x 7	1	40.080
12	Passfeder 8 x 7 x 28	1	40.459
13	Kugellager 6206 - 2Z	1	40.538
14	Innensechskantschraube M 6 x 30	4	43.037
19	Schraube M 4 x 12	4	41.489
20	Schelle für Lüfterrad 112	2	40.535
21	Schraube M 4 x 12	4	41.489
22	Erdungsschraube kpl.	1	43.038
23	Schalter mit Drucktasten	1	42.644
24	Kunststoffschraube 4,0 x 16	6	43.417
25	Bock für Schalter	1	42.608
26	Kunststoffschraube 5,0 x 25	6	41.414
28	Kunststoffschraube 3,5 x 20	2	43.415
29	Lüsterklemme 5-pol.	1	43.326 1
30	Schütz 100-C12KN10 3x400V 50/60 Hz	1	46.005 1
31	Schaltkasten Unterteil	1	42.606
32	Schaltkasten Deckel	1	42.607
33	Steuerplatine Abschaltverz. 400V / 50Hz	1	42.563
34	Klemmrahmen mit Schalterabdichtung	1	43.453
36	Blechschrabe 3,5 x 16	2	44.161
37	PG 16-Verschraubung	1	41.419 1
38	Dichtung für Schaltkastendeckel	1	42.607 1
39	Gegenmutter für PG9-Verschraubung	1	41.087 1
40	Gegenmutter für PG16-Verschraubung	1	44.119
41	PG 9 - Verschraubung	1	43.034
42	Überstromauslöser 3-polig 11,3-16A	1	42.641
50	Motor compl. without switch	1	24.060
51	Schaltkasten kpl. Pos. 23 - 42		42.631

Transmission unit

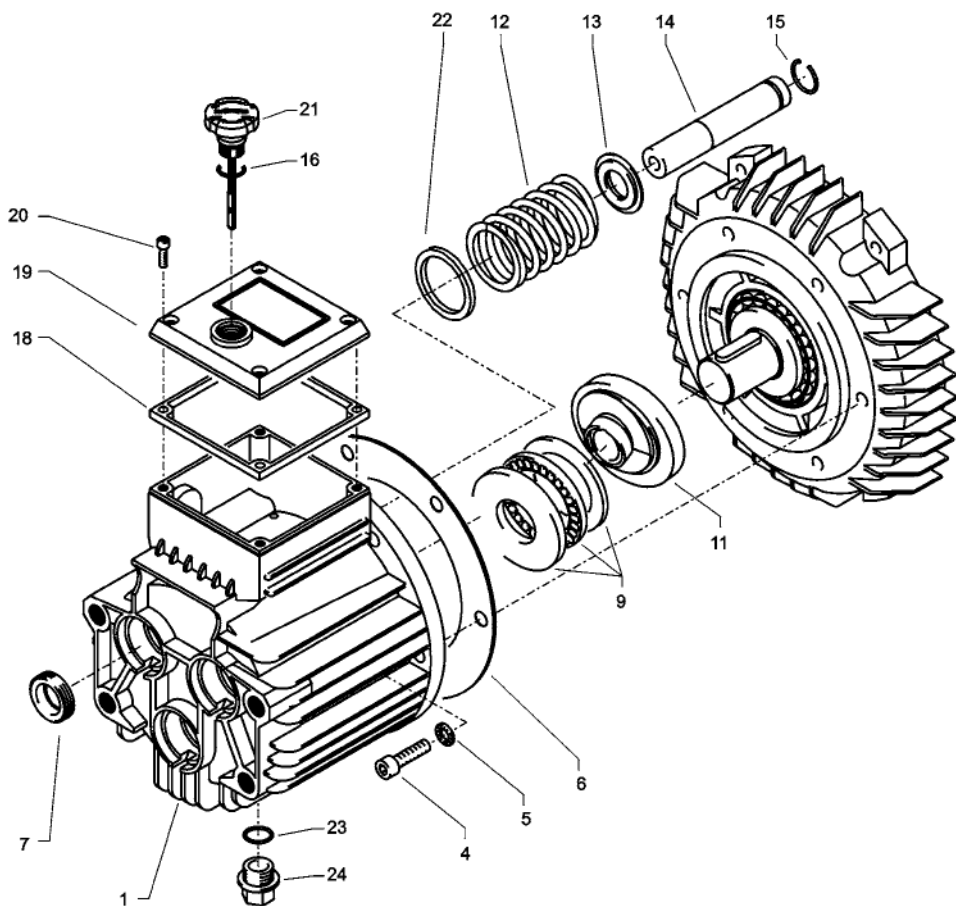

quadro 800 TST - 1200 TST

Spare parts list KRÄNZLE quadro 800 TST - 1200 TST Pump transmission unit for AQ-Pump

No	Description	Qty.	Ord.-No
1	Ölgehäuse	1	40.501
4	Innensechskantschraube M 8 x 30	6	41.036 1
5	Sicherungsscheibe	6	40.054
6	Flachdichtung	1	40.511
7	Öldichtung 20 x 30 x 7	3	40.044 1
9	Axial-Zylinderrollenlager AQ-Pumpe	1	40.524
11.1	Taumelscheibe AQ 9,5° bei quadro 800 TST	1	40.523-9,5
11.2	Taumelscheibe AQ 10,8° bei quadro 1000 TST + 1000 TS	1	40.523-10,8
11.3	Taumelscheibe AQ 12,75° bei quadro 1200 TST + 1200 TS	1	40.523-12,75
12	Plungerfeder	3	40.506
13	Federdruckscheibe	3	40.510
14	Plunger 20 mm (lang)	3	40.505
15	Sprengring	3	40.048
16	O-Ring 14 x 2	1	43.445
18	Flachdichtung	1	41.019 3
19	Deckel flach für Ölgehäuse	1	41.023 1
20	Innensechskantschraube M 5 x 12	4	41.019 4
21	Ölmessstab AQ	1	42.623
22	Stützscheibe für Plungerfeder	3	40.513
23	O-Ring 13,94 x 2,62	1	42.167
24	Ölablassstopfen R 3/8"	1	42.019
	Ölgehäuse AQ kpl. ohne Taumelscheibe		40.514
	Pos. 1, 4-7, 12-17, 22		

Unloader valve and pressure switch

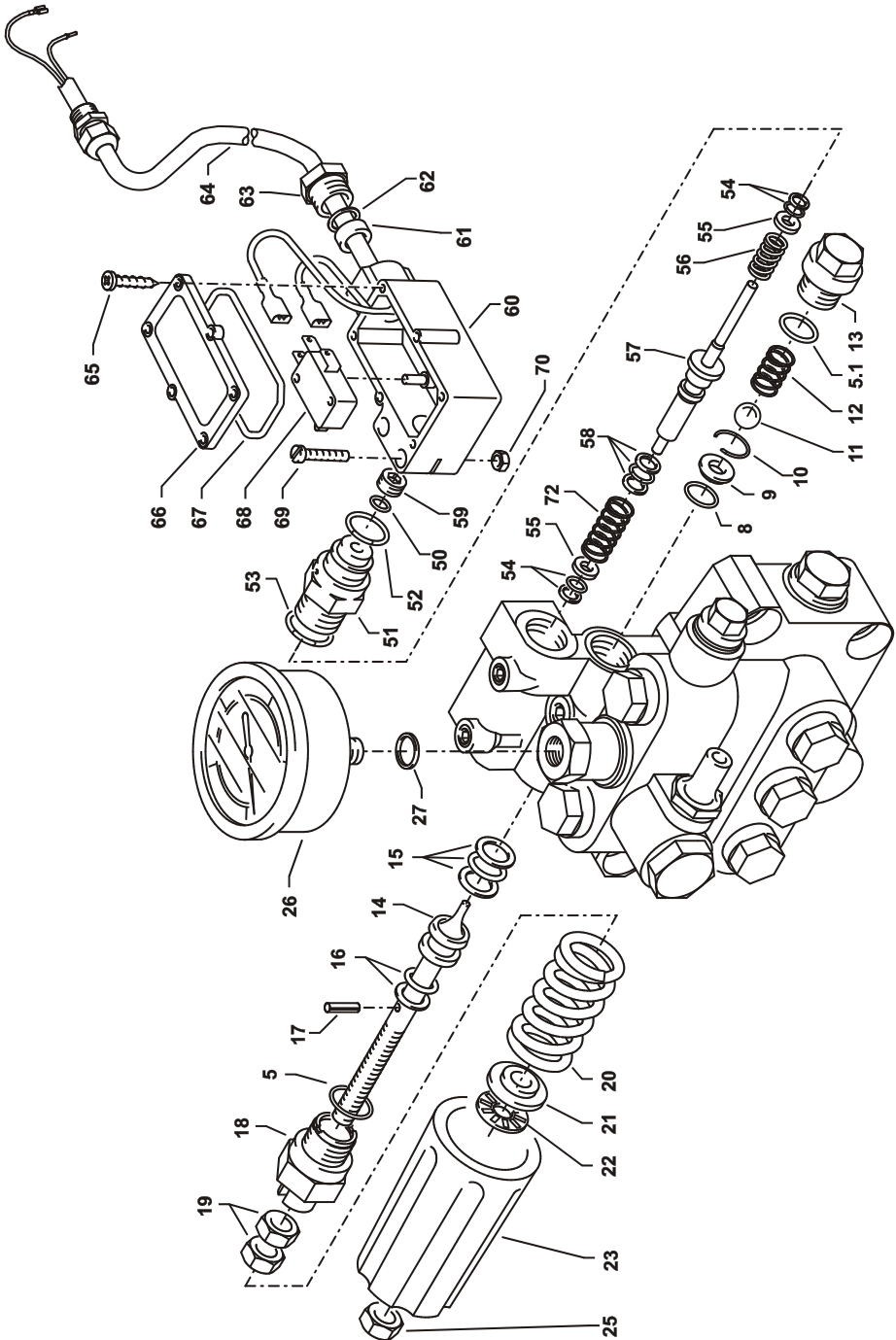

quadro 800 TST - 1200 TST

Spare parts list quadro 800 TST - 1200 TST Unloader valve and pressure switch

No	Description	Qty.	Ord.-No	No	Description	Qty.	Ord.-No
5	O-Ring 16 x 2	1	13.150	55	Stützscheibe	2	15.015 1
5.1	O-Ring 13,94 x 2,62	1	42.167	56	Edelstahlfeder	1	15.016
8	O-Ring 11 x 1,44	1	12.256	57	Steuerstößel	1	15.010 2
9	Edelstahlsitz	1	14.118	58	Parbaks 7 mm	1	15.013
10	Sicherungsring	1	13.147	59	Stopfen M 10 x 1 (durchgebohrt)	1	13.385 1
11	Edelstahlkugel	1	13.148	60	Gehäuse Elektroschalter	1	15.007
12	Edelstahlfeder	1	14.119	61	Gummimanschette PG 9	1	15.020
13	Verschlusschraube	1	14.113	62	Scheibe PG 9	1	15.021
14	Steuerkolben	1	14.134	63	Verschraubung PG 9	1	15.022
15	Parbaks 16 mm	1	13.159	64	PVC-Kabel 2x 1,0 mm ²	1	42.505
16	Parbaks 8 mm	1	14.123	65	Blechschraube 2,8 x 16	6	15.024
17	Spannstift	1	14.148	66	Deckel Elektroschalter	1	15.008
18	Kolbenführung spezial	1	42.105	67	O-Ring 44 x 2,5	1	15.023
19	Kontermutter M 8 x 1	2	14.144	68	Mikroschalter	1	44.262
20	Ventilfeder rot bei quadro 800	1	14.125 1	69	Zylinderschraube M 4 x 20	2	15.025
20.1	Ventilfeder schwarz bei quadro 1000 und 1200	1	14.125	70	Sechskant - Mutter M 4	2	15.026
21	Federdruckscheibe	1	14.126	72	Druckfeder 1 x 8,6 x 30	1	40.520
22	Nadellager	1	14.146	Repair kits:			
23	Handrad	1	14.147	Repair kit			
25	Elastic-Stop-Mutter M 8 x 1	1	14.152	Pressure switch			
26	Manometer 0-400 Bar	1	15.039 4	1x Pos. 51, 1x Pos. 52, 1x Pos. 53,			
27	Aluminium-Dichtring	2	13.275	3x Pos. 54, 1x Pos. 55, 1x Pos. 56,			
50	O-Ring 3,3 x 2,4	1	12.136	1x Pos. 57, 1x Pos. 58, 1x Pos. 59			
51	Führungsteil Steuerstößel	1	15.009 1	Pressure switch compl. No. 54 - 70			
52	O-Ring 13 x 2,6	1	15.017	41.300 5			
53	O-Ring 14 x 2	1	43.445				
54	Parbaks 4 mm	2	12.136 2				

Valve housing

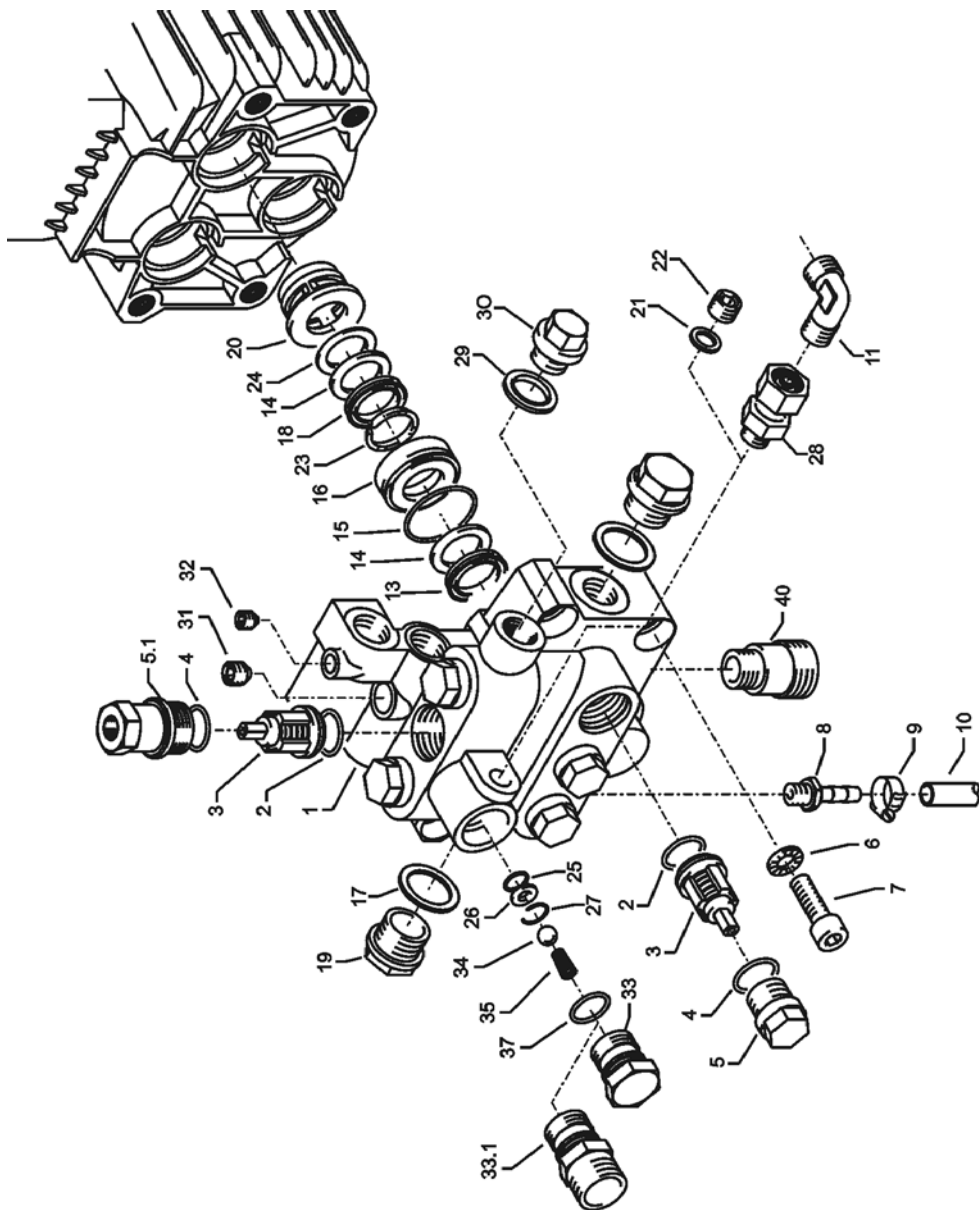

quadro 800 TST - 1200 TST

Spare parts list KRÄNZLE quadro 800 TST - 1200 TST Valve housing for integrated AQ-pump

No	Description	Qty.	Ord.-No	No	Description	Qty.	Ord.-No
1	Ventilgehäuse AQ mit integ. UL und Druckschalter	1	40.503 5	33	Ausgangsteil für quadro 800, 1000, 1200 TST	1	40.522
2	O-Ring 18 x 2	6	40.016	33.1	Ausgangsteil M22x1,5 für quadro 1000, 1200 TS	1	40.522 1
3	Einlaß- /Auslaß- Ventil	6	42.024	34	Edelstahlkugel Ø10	1	12.122
4	O-Ring 21 x 2	6	42.025	35	Rückschlagfeder „K“	1	14.120 1
5	Ventilstopfen	5	42.026	37	O-Ring 18 x 2	1	43.446
5.1	Ventilstopfen mit R 1/4" IG	1	42.026 2	40	Wassereingang R3/8" AG	1	41.016
6	Sicherungsring	4	40.032		Repair kits:		
7	Innensechskantschraube M 12 x 45	4	40.504		Repair kit for sleeves		40.065 1
8	Schlauchnippel R3/8" x 6	1	42.634		consisting of: 3x Pos. 13; 6x Pos. 14;		
9	Schlauchschele 7 - 10	1	44.054		3x Pos. 15; 3x Pos. 16; 3x Pos. 18;		
10	Chemiesaugschlauch mit Filter	1	42.621		3x Pos. 20; 3x Pos. 23		
11	Winkel 12L x 12L	1	42.630		Repair kit for sleeves without brass parts		40.517
13	Gewebemanschette	3	40.023		consisting of:		
14	Backing 20 mm	6	40.025		3x Pos. 13; 6x Pos. 14; 3x Pos. 15;		
15	O-Ring 31,42 x 2,62	3	40.508		3x Pos. 18; 3x Pos. 23		
16	Leckagering 20 x 36 x 13,3	3	40.509				
17	Cu-Dichtung 21 x 28 x 1,5	2	42.039				
18	Gummimanschette	3	40.512				
19	Verschlusschraube R 1/2"	2	42.032				
20	Distanzring mit Abstützung	3	40.507				
21	Aluminium-Dichtring bei quadro TS	2	13.275				
22	Verschlussstopfen bei quadro TS	1	13.181				
23	Druckring 20 mm	3	40.021				
24	Zwischenring 20 mm	3	40.516				
25	O-Ring 11 x 1,5	1	12.256				
26	Edelstahlsitz Ø 7	1	14.118				
27	Sprengring	1	13.147				
28	Ausgangsteil Pumpe R1/4" x 12	1	44.215				
29	Dichtring 17 x 22 x 1,5 (Kupfer)	1	40.019				
30	Stopfen 3/8"	1	40.018				
31	Dichtstopfen M 10 x 1	1	43.043				
32	Dichtstopfen M 8 x 1	2	13.158				

Hose drum

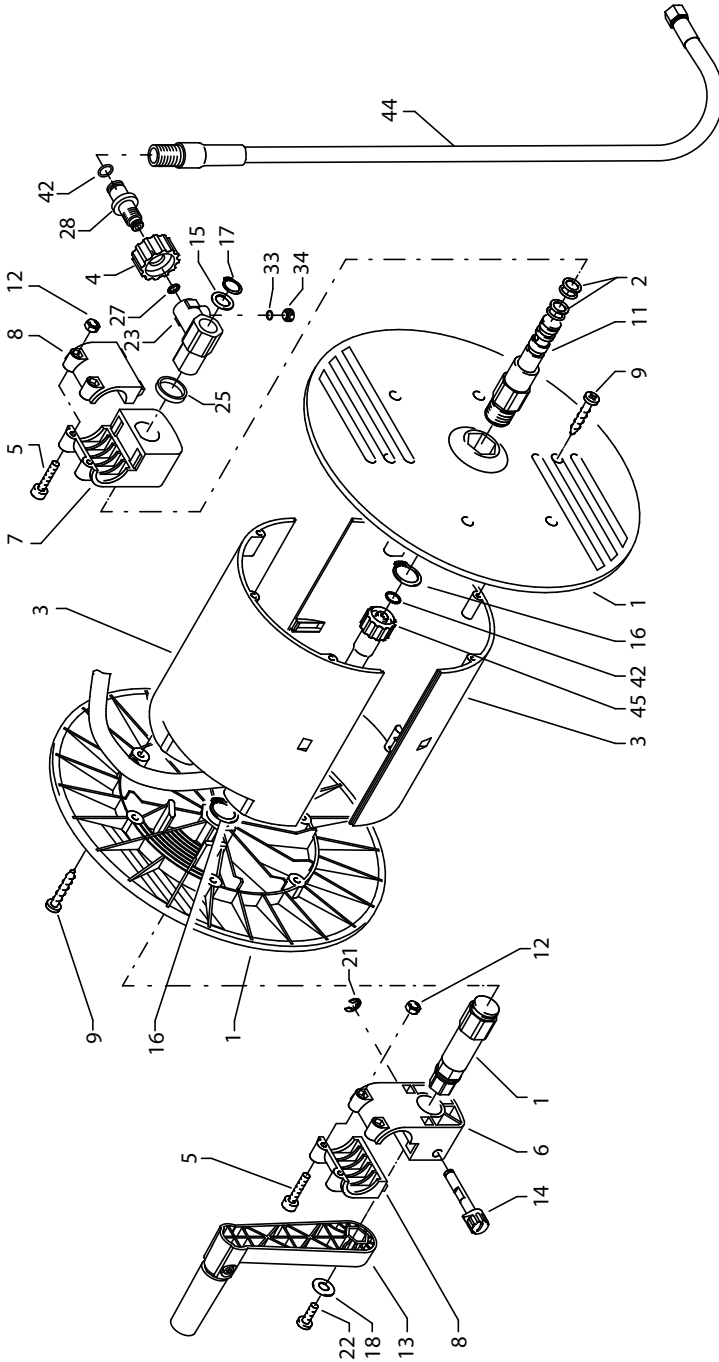

quadro 800 TST - 1200 TST

Spare parts list KRÄNZLE quadro 800 TST - 1200 TST Hose drum

No	Description	Qty.	Ord.-No	No	Description	Qty.	Ord.-No
1	Seitenschale Schlauchführung	1	40.302	23	Drehgelenk	1	40.167
2	Seitenschale Wasserführung	1	40.301	24	Anschlusssteil	1	40.308
3	Trommel Unterteil	1	40.304	25	Distanzring	1	40.316
4	Trommel Oberteil	1	40.303	27	O-Ring 6,5 x 2	1	40.585 2
5	Innensechskantschraube M 4 x 25	4	40.313	28	Anschlussstück	1	40.308
6	Lagerklotz mit Bremse	1	40.306	33	O-Ring 6 x 1,5	1	13.386
7	Lagerklotz links	1	40.305	34	Stopfen M 10 x 1	1	13.385
8	Klemmstück	2	40.307	40	Überwurfmutter	1	13.276 2
9	Kunststoffschraube 5,0 x 20	12	43.018	42	O-Ring 9,3 x 2,4	4	13.275
10	Antriebswelle	1	40.310	44	Verbindungsschlauch	1	42.624
11	Welle Wasserführung	1	40.311	45	Hochdruckschlauch NW 8 20 m	1	41.083
12	Elastic-Stop-Mutter M 4	4	40.111	Hose drum compl. without hose			
13	Handkurbel klappbar	1	40.320 0				
14	Verriegelungsbolzen	1	40.312				
15	Scheibe MS 16 x 24 x 2	1	40.181				
16	Wellensicherungsring 22 mm	2	40.117				
17	Wellensicherungsring 16 mm	1	40.182				
18	Unterlegscheibe Ø 6,4	1	50.189				
20	Parbaks 16 mm	2	13.159				
21	Sicherungsscheibe 6 DIN6799	1	40.315				
22	Schraube M 5 x 10	1	43.021				

Starlet II

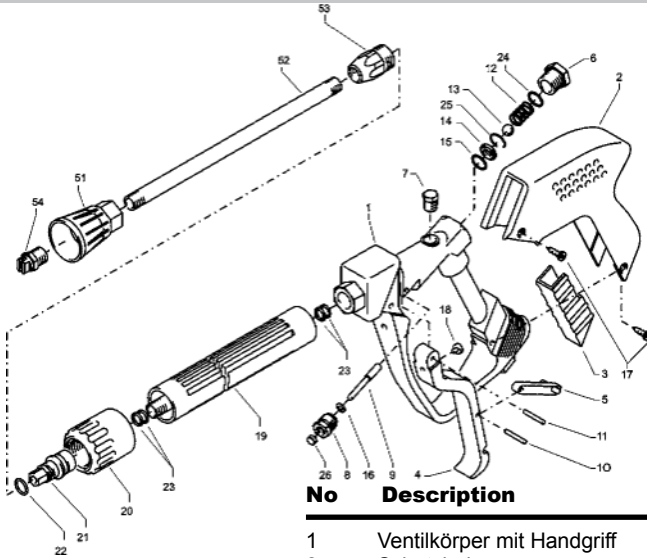

No	Description	Qty.	Ord.-No
1	Ventilkörper mit Handgriff	1	12.294
2	Schutzhülse	1	12.295
3	Abdeckschutz	1	12.296
4	Betätigungshebel grau	1	12.298 3
5	Sicherungshebel	1	12.149
6	Abschlusschraube M 16 x1	1	12.247
7	Stopfen	1	12.287
8	Gewindeführungshülse Ø3 R 1/4" AG	1	12.250 1
9	Aufsteuerbolzen Ø3	1	12.284 1
10	Stift	1	12.148
11	Lagernadel	1	12.253
12	Edelstahlfeder	1	12.246
13	Edelstahlkugel 8,5	1	12.245
14	Edelstahlsitz Ø7	1	14.118
15	O-Ring 11 x 1,44	1	12.256
16	O-Ring 2,84 x 2,62	1	12.136 1
17	Blechschaube 3,9 x 8,5	4	41.079
18	Druckstück	1	12.252
19	Rohr kunststoffspritzt bds. R 1/4" AG	1	15.004 5
20	Überwurfmutter ST 30 M22 x 1,5 IG	1	13.276 1
21	Außen-Sechskant-Nippel R 1/4" IG	1	13.277 1
22	O-Ring 9,3 x 2,4	1	13.273
23	Aluminium-Dichtring	4	13.275
24	O-Ring 15 x 1,5	1	12.129 1
25	Sicherungsring	1	12.258
26	Gleitschuh Ø3	1	12.289 1
51	Düsenschutz	1	26.002
52	Rohr 600 mm; bds. R1/4"	1	12.385 2
53	ST 30 Nippel M 22 x 1,5 / R1/4" m. ISK	1	13.370
54	Flachstrahldüse 2504 (bei quadro 800)	1	D2504
54.1	Flachstrahldüse 2505 (bei quadro 1000)	1	D2505
54.2	Starlet Düse 2507 (elongation 200)	1	D2507
	Repair kit: „Starlet II“		12.299
	consisting of: 1x Position: 8, 9, 13-16, 24-26		

Turbokiller

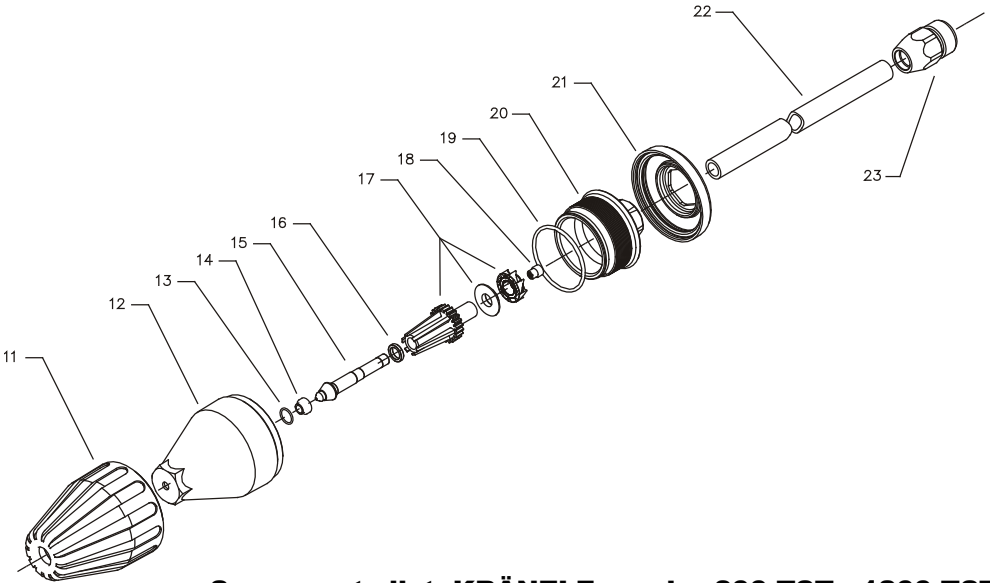

Spare parts list KRÄNZLE quadro 800 TST - 1200 TST Turbokiller

No	Description	Qty.	Ord.-No
11	Sprühkörperschutz	1	41.528
12	Sprühkörper	1	41.529
13	O-Ring 6,88 x 1,68	1	41.521
14	Düsensitz	1	41.522
15	Düse 04 für quadro 800	1	41.532 0
15.1	Düse 055 für quadro 1000	1	41.532
15.2	Düse 08 für quadro 1200	1	41.537
16	Ring	1	41.533
17	Rotor	1	41.534
18	Stabilisator	1	41.524
19	O-Ring 41 x 1,78	1	41.538
20	Deckel	1	41.539
21	Deckelschutz	1	41.540
22	Rohr 500 mm lang; bds. R1/4"	1	12.385 1
23	Nippel M22x1,5 x R1/4" IG	1	13.370
	Turbokiller 04 compl. with lance		41.072
	Turbokiller 055 compl. with lance		41.072 4
	Turbokiller 08 compl. with lance		41.072 8
	Repair Kit Turbokiller 04		41.096 9
	Repair Kit Turbokiller 055		41.097 1
	Repair Kit Turbokiller 08		41.097 3

Wiring diagram

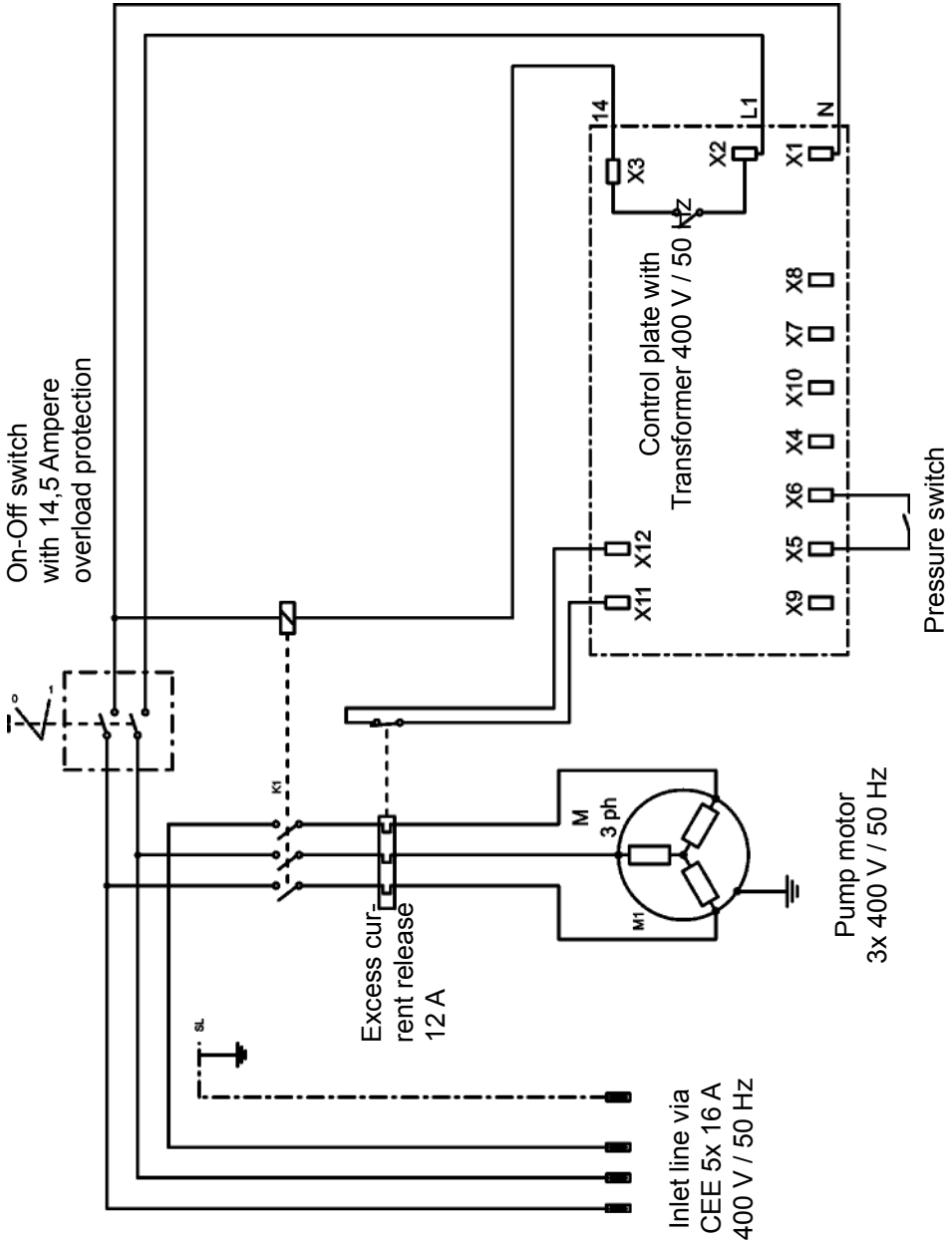

General rules

Inspections

The machine must be inspected according to the “Guidelines for Liquid Spray Devices” at least once every 12 months by a qualified person, to ensure that continued safe operation is guaranteed.

The results of the inspection are to be recorded in writing.

This may be done in any form.

Accident prevention

The machine is designed for accidents to be impossible if used correctly.

The operator is to be notified of the risk of injury from hot machine parts and the high pressure water jet. The “Guidelines for Liquid Spray Devices” must be complied with. (see pages 16 and 17)

Check the oil level at the oil dip stick prior to each use (see also page 11).

(Ensure horizontal position!)

Oil change:

The first oil change should be carried out after approximately 50 operating hours, then every year or after 1000 operating hours. If the oil turns grey or white, you must certainly change the oil of your high pressure pump.

Open the oil discharge screw at the bottom of the device over a collection reservoir.

Put the machine into a horizontal position to drain the oil. The oil is to be caught in the reservoir and disposed of in an approved manner.

New Oil: 1,0 l -

Motor oil: 10/W60 SAE halfsynthetic oil



Inspection report

for KRÄNZLE - High Pressure Cleaners The high pressure cleaner must be inspected by an expert every 12 months.

Appliance No.:

Type of appliance:

The following must be checked:

1. Safety features

- a) Manometer
- b) Safety valve (pressure control)
- c) Operating pressure
- d) Cut out pressure (max. 10% above operating pressure)
- e) Low pressure with closed gun

2. General condition

- a) High pressure hose
- b) Cable, plug, switch (VDE)
- c) Spray gun, spray accessories.
- d) Motor
- e) Oil level

The information in the operating instructions are a part of the inspection

Result of inspection:	Date of inspection:	Faults rectified, Stamp and signature
<input type="text"/>	<input type="text"/>	<input type="text"/>
<input type="text"/>	<input type="text"/>	<input type="text"/>
<input type="text"/>	<input type="text"/>	<input type="text"/>

Excerpt from the Guidelines for Liquid Spray Equipment (ZH 1/46) by the Central Office of the Professional Trade Association.

Inspection:

Liquid spray equipment should be inspected for safe operation by a qualified person whenever necessary, but no less than every 12 months. The maker's or supplier's instructions must be followed. The inspection intervals may be extended if the equipment is not in active use.

The results of inspections must be recorded in writing and presented to the respective authorities on demand. There is no set form for these records.

Warranty

Guarantee

The guarantee is only valid for material and manufacturing errors. Wearing does not fall within this guarantee.

The instructions in our operating manual must be complied with. The operating instructions form part of the guarantee. The Guarantee is void if other parts are used than genuine Kränzle accessory parts or genuine Kränzle spare parts.

For high-pressure cleaners sold to the user the guarantee period is 24 month.

For high-pressure cleaners sold for industrial use the guarantee period is 12 month. In the case of a guarantee please contact your dealer or authorized seller delivering accessories and your purchase receipt. You can find them in the internet under www.kraenzle.com.

The guarantee is also void if the machine is used with exceeding the temperature and speed limits, a voltage below the required rating, with less than the required amount of water or with dirty water. Pressure gauge, nozzle, valves, sleeves, high pressure hose and spray equipment are wear parts and are not covered by the warranty.

Notes

kränzle®

High-pressure-cleaners
Hochdruckreiniger
Nettoyeurs à Haute Pression



I. Kränzle GmbH
Elpke 97 . 33605 Bielefeld

EC declaration of conformity

We hereby declare,
that the high-pressure models:

Kränzle quadro 800/1200 TST
Kränzle quadro 1000/1200 TS

(techn. documentation available from):

Manfred Bauer, Fa. Josef Kränzle
Rudolf-Diesel-Str. 20, 89257 Illertissen

Nominal flow:

K quadro 800 TST: 798 l/h
K quadro 1000 TST: 960 l/h
K quadro 1200 TST: 1140 l/h

comply with the following guidelines and
specifications and their amendments for
high-pressure cleaners:

Machine guideline 2006/42/EEC
Specification for electromagnetic
compatibility 2004/108/EEC
Outdoor noise directive 2005/88/EC,
Art. 13, High-pressure water jet machines
Appendix 3, part B, chapter 27

Sound power level measured:
guaranteed:

89 dB (A)
91 dB (A)

Applied conformity evaluation
procedures:

annex V, noise directive 2005/88/EC

Applied specifications and
standards:

EN 60 335-2-79 :2009
EN 55 014-1 :2006
EN 55 014-2 / A2:2008
EN 61 000-3-2 : 2006
EN 61 000-3-3 : 2008

Bielefeld, den 29.02.12

A handwritten signature in cursive script, reading 'Josef Kränzle', written over a horizontal line.

Kränzle Josef
(Managing Director)



I. Kränzle GmbH
Elpke 97
D - 33605 Bielefeld

Subject to technical modifications. Order no. 30.260 1

Reprint only allowed with the authorisation of Kränzle.

As date of 10/06/2014

■ Made
■ in
■ Germany